

**WARNING: THIS PROCEDURE CONTAINS
HAZARDOUS OPERATIONS**



**HESSI SPACECRAFT
LAUNCH VEHICLE MATE**
HSI_MIT_024D.doc
2001-Jun-26

As Run on: _____ (Date/Time)

By _____ (Test Conductor)

DOCUMENT REVISION RECORD

Rev.	Date	Description of Change
A	11/13/00	Initial Version
B	11/15/00	RFA Disassembly Updated
C	12/30/00	1.4 Removed 30 SW/SE task. 4.4. Add steps to setup the hydraset 4.5 Add steps for lift/rotate preparations 4.6 Deleted 30 SW/SE verification.. 4.6. Step to integrate RFA to Spacecraft should be from Section 6.3.2. 4.6 Replaced the 11 th block to the 14 th block with MIT-21, Section 6.8, Removing SC from Flotron. Deleted verification step in End of hazardous operations.. Start and End haz ops. There is a step to end hazardous operations. However, there was not step to start hazardous operations, set up control area, change lights to amber and make facility announcement. Also for end of haz ops, need to add removal of control area, change lights to green and make facility announcement.
D	6/26/01	Removed NASA Safety Concurrence (since in 1555) 1.1 Added "demating" 1.3 Added "demating..." 2.3 Removed hydraset operations 4.2 Removed hydraset from required equipment 4.4 Removed crane setup with hydraset instructions. 4.5 Replace hydraset with crane 4.7 Added a step to tiedown pigtail harness. 4.8 Removed bottle jacks. Added a ladder to step on. 4.9 Remove RFA side plates before moving Byrdmobile. 4.9 Remove C-plates and Titanium links separately. 4.10 New section describing putting on the RFA

Project Manager: _____
 PETER HARVEY Date

Lead Mechanical Engineer: _____
 Dr. DAVID PANKOW Date

System Engineer: _____
 DAVID CURTIS Date

Quality Assurance: _____
 RON JACKSON Date

Table of Contents

DOCUMENT REVISION RECORD 2

1. INTRODUCTION..... 4

1.1 SCOPE 4

1.2 REFERENCE DOCUMENTS 4

1.3 APPLICATION 4

1.4 PERSONNEL..... 4

2. HAZARDS AND PRECAUTIONS..... 4

2.1 HOISTING PRECAUTIONS 4

2.2 CRANE OPERATION 4

2.3 HYDRASET OPERATION..... 5

2.4 LAUNCH VEHICLE 5

3. SAFETY..... 6

3.1 RESPONSIBILITY..... 6

3.2 SAFETY NOTIFICATION. 6

3.3 PRE OPERATION BRIEFING. 6

3.4 SUSPENDED LOADS 6

3.5 CERTIFICATION 6

3.6 CRANE OPERATION 6

3.7 TOOL TETHERING..... 6

4. LAUNCH VEHICLE MATE OPERATION 7

4.1 REQUIRED PERSONNEL..... 7

4.2 REQUIRED EQUIPMENT 7

4.3 REQUIRED CONTROL AREA..... 7

4.4 SPACECRAFT INSTALLATION TO BYRDMOBILE..... 8

4.5 PAYLOAD ATTACHMENT FITTING (PAF) INSTALLATION TO SPACECRAFT 9

4.6 SPACECRAFT TO VEHICLE MATING PROCEDURE..... 9

4.7 REMOVAL OF ROTATION FIXTURE ADAPTER ASSEMBLY AND BYRD-MOBILE 9

1. INTRODUCTION

1.1 Scope

This procedure describes the operations necessary for mating and demating the HESSI spacecraft to the Pegasus-XL Launch Vehicle at Vandenberg AFB. This section describes the necessary equipment, personnel and procedures for handling the spacecraft during these operations.

1.2 Reference Documents

EWR 127-1	Range Safety Requirements
K-SF-0003.7	KSC Off-Site Facility Ground Safety Plan
NSS/GO-1740.9	NASA Safety Standard for Lifting Devices and Equipment
MIL-STD-1686	CLASS I and NHB5300.4(3L)
HSI_MIT_021	Spacecraft Handling Procedures

1.3 Application

The HESSI spacecraft will be mated to the Pegasus launch vehicle at VAFB building 1555. Using procedures in HSI_MIT_021, the spacecraft is transferred from its dolly to the rollover device and rotated to horizontal. The steps in this document include:

1. Installing the Payload Attach Fitting (PAF)
2. Transferring the spacecraft from the Rollover Fixture to the ByrdMobile;
3. Mating to the Launch Vehicle;
4. Demating the spacecraft and Byrdmobile;
5. Demating the spacecraft from the Launch Vehicle.

1.4 Personnel

Lead Mechanical Engineer (LME). The Lead Mechanical Engineer, David Pankow, is responsible for the mechanical operations of the HESSI spacecraft. No mechanical activity or operation may be performed on the spacecraft without the knowledge and approval of the LME or the LME's designee.

Systems Engineer (SE). The SE is responsible for the electrical operations of the HESSI spacecraft. No electrical activity or operation may be performed on the spacecraft without the knowledge and approval of the SE or the SE's designee.

Quality Assurance (QA). QA is responsible for monitoring all Spacecraft activities with respect to witnessing and inspecting of critical procedural steps and inspection points.

Crane Operator. The CO shall be responsible for operating the crane at any time during the mating procedures.

OSC Personnel. Responsible for all OSC related operations

2. HAZARDS AND PRECAUTIONS

2.1 Hoisting Precautions

All hoisting equipment; including cranes, hydrasets and load bearing attachments shall have in date servicing and proof load verification. Each lifting line; including bolts and shackles shall be inspected before use. Slings shall show no evidence of damage, kinking or misuse. Unapproved devices shall not be used for lifting applications.

2.2 Crane Operation

The LME or the LME's designee will give all instructions to the CO (Crane Operator) for crane movements. Only certified crane operators shall operate the crane. During all crane operation, one person will be stationed at the crane shut off switch to prevent runaway conditions.

2.3 Hydraset Operation

No hydraset will be used in these operations.

2.4 Launch Vehicle

The make-before-break rule shall be strictly adhered to when grounding cables are removed from or attached to the spacecraft. The spacecraft shall be properly grounded with a grounding cable prior to lifting the spacecraft and shall remain grounded until the spacecraft is reattached to a grounded surface. All personnel within 1 meter of the spacecraft and launch vehicle shall be properly grounded.

3. SAFETY

3.1 Responsibility.

The LME will be responsible for ensuring safety while conducting mechanical handling operations outlined in this procedure. The LME will ensure compliance with all safety regulations or practices in effect during these operations. Areas in which lifting and handling operations are taking place will be cordoned off and non-essential personnel will be evacuated. Hard hats will be required inside the safety zone during lift operations. Steel toe safety shoes will be worn by personnel working near the suspended loads.

3.2 Safety Notification.

The LME will notify launch site safety (30 SW/SE) and/or appropriate personnel 24 hours prior to start of procedure.

3.3 Pre Operation Briefing.

The LME is responsible for establishing the safety precautions necessary for each specific procedure and verifying that the precautions are in place before the procedure is started. The Lead Mechanical Engineer shall hold a Pre-Task Briefing before the procedure begins. The Pre-Task Briefing shall include the following subjects:

1. Details of the task to be completed.
2. Potential Hazards Involved.
3. Use of Protective Equipment.
4. Identification of a Safety Monitor.

3.4 Suspended Loads

This procedure contains lifting operations where personnel may be required to work near a suspended load. Personnel will not be allowed under the suspended load at any time and only two persons shall be allowed to work near a suspended load.

Within this procedure hazardous lift operations have been marked with a warning statement.

All personnel inside the safety zone of a lift shall wear hard hats and safety shoes during those operations. Personnel working near or over flight hardware shall remove hard hats.

The work near suspended loads will be limited to guiding by hand, the last three or four inches of a mating or demating operation.

Tag line(s) shall be attached to lift fixtures so that the suspended load can be guided for better control.

3.5 Certification

All hoisting equipment, including cranes, hydrasets and load bearing attachments shall be current (within one year) load test tags and the load to be lifted/supported shall be within the working range of the certification. Hoisting equipment shall be tested annually in accordance with NASA Safety Standard NSS/GO-1740.9B and EWR 127-1. Each lifting line, including bolts and shackles shall be inspected before use. Slings shall show no evidence of damage, kinking or misuse. Unapproved devices shall not be used for lifting applications.

3.6 Crane Operation

The LME or the LME's designee will give all instructions to the crane operator for crane movements. Only certified crane operators shall operate the crane.

3.7 Tool Tethering

Tools used above the spacecraft will be tethered at all times.

4. LAUNCH VEHICLE MATE OPERATION

4.1 Required Personnel

The following personnel are involved:

- 1 Lead Mechanical Engineer
- 1 Crane Operator
- 1 Mechanical Technician
- 1 Electrical Technician
- 1 Quality Assurance
- Launch Vehicle Personnel as Required
- 1 Operational Safety Officer

4.2 Required Equipment

The equipment used in these critical operations shall be capable of handling at least twice the expected load. The following table should be completed before the operations involving these items.

Item	Rating (lb)	Required Load (lb)
Crane		
Lifting Sling & Spreader		
Rotation Fixture Assy		
Flotron Rotation		
Byrd-Mobile		

4.3 Required Control Area

The area (approx. 15' X 15') where the lift is to occur shall be roped off and only essential personnel will be allowed in the control area. It will be at the discretion of the LME and the launch vehicle task leader to determine who is essential to enter the control area. The number of essential personnel will be approved by 30 SW/SE Safety.

4.4 Crane Setup with Hydraset

Not used.

4.5 Lift/Rotate Preparations

- The Lift Coordinator shall conduct a pre-task briefing before the procedure begins.
- Attach the following components to the crane: Spreader Beam, Wire Rope Sling (72 in.) with Shackles.
- Attach ground line to the Byrdmobile.
- Attach a travelling ground strap to the spacecraft.

4.6 Spacecraft Installation to Byrdmobile

BEGINNING OF HAZARDOUS OPERATIONS

WARNING : Performing the procedure below may result in severe personnel injury, loss of life, or major equipment damage if not followed exactly.

WARNING: PERSONNEL NOT PERMITTED TO STAND UNDER SUSPENDED LOAD

- Prior to the operation, setup control area using area warning signs and/or barricades.
- Change warning light to amber and announce over the Public Address system that the spacecraft lift is commencing.
- Disconnect Spectrometer Vacuum Pump using procedure HSI_MIT_023. **IMPORTANT: SPACECRAFT MAY NOT BE DISCONNECTED FROM VACUUM PUMP FOR MORE THAN 15 HOURS.**
- Install the HESSI Rotation Fixture Adapter frame on the spacecraft in accordance with HSI_MIT_021, Section 6.3.2 Integrate RFA to Spacecraft.
- Using the OSC Overhead Crane, transfer HESSI from the spacecraft dolly to the Flotron turnover fixture and secure in accordance with HSI_MIT_021, section 6.3 Lifting the Spacecraft and section 6.6 Placing Spacecraft on Flotron.
- Rotate the spacecraft to a horizontal position in accordance with HSI_MIT_021, section 6.7 Rotating Spacecraft on Flotron.
- Install 4 ea. Hoist Rings (P/N 2994T64) at corners of the Rotation Fixture Adapter (AM-617648) using .375-16 Grade 8 Hex Nut. Torque to 12 ft-lb.
- Locate Byrdmobile in desired location and verify it is configured for S/C mounting.
- Remove spacecraft from Flotron using HSI_MIT_021, section 6.8.
- Move S/C to the Byrdmobile. Verify ground strap is tensioned during the operation.
- Lower S/C with crane to the ByrdMobile. Install securing bolts and verify.
- Disconnect slings from S/C and raise crane to clear S/C. Insure that the slings are tensioned as they are raised to prevent contact with the Solar Arrays.
- Remove tagline and travelling ground as required.

END OF HAZARDOUS OPERATION

- Connect Spectrometer Vacuum Pump using procedure HSI_MIT_022.
- Remove area warning signs and/or barricades.
- Change warning light to green and announce over the Public Address system that the lift is complete.

4.7 Payload Attachment Fitting (PAF) Installation to Spacecraft

- The PAF shall be attached to the spacecraft per OSC procedure PWP-5040, 38" Separable Payload Installation procedure and A70370, HESSI/Pegasus Payload Mechanical ICD.
- Attach and tiedown pigtail harness.

4.8 Spacecraft to Vehicle Mating Procedure

- Disconnect Spectrometer Vacuum Pump using procedure HSI_MIT_023. **IMPORTANT: SPACECRAFT MAY NOT BE DISCONNECTED FROM VACUUM PUMP FOR MORE THAN 15 HOURS.**
- Prior to the operation, set up control area using area warning signs and/or barricades.
- Position the spacecraft, mounted on the Byrdmobile with the PAF installed, approximately 6" from the Pegasus-XL third stage avionics section.
- Raise the Byrdmobile with the 4 hand cranks until the PAF bolt circle aligns horizontally with the Pegasus avionics section bolt circle.
- Using the Y axis crank, move the spacecraft to within 1/8" of the avionics section. Align the spacecraft bolt hole pattern with the avionics section hole pattern using the angular adjustment crank located on the side of the mating dolly. Position ladder next to spacecraft to allow personnel to work without affecting height adjustments.
- Start the fasteners, specified in OSC procedure PWP-5040, 38" Separable Payload Installation procedure which hold the spacecraft and separation ring to the launch vehicle. Once fasteners have been started, close gap between PAF and avionics section using the Y axis crank. Complete fastener installation and torquing per referenced procedure.

4.9 Removal of Rotation Fixture Adapter Assembly and Byrdmobile

- After the interface fasteners have been properly torqued, and approval to proceed has been given by OSC personnel, loosen, but do not remove fasteners holding the spacecraft to the lifting frame.
- Lower the Byrdmobile 1/8" to allow the spacecraft weight to be transferred from the Byrdmobile to the launch vehicle.
- Supporting the upper crossbars of the RFA, remove fasteners and bars.
- Remove the fasteners holding the two RFA side plates to the lower crossbars.
- Remove the fasteners holding the two RFA side plates to the RFA C-plates.
- Remove bolts holding side plates to Byrd-mobile. Remove plates.
- Position one person at each corner of the Byrd-mobile and one person to watch for clearance. Push the Byrd-Mobile from the spacecraft. Some additional adjustments to the position of the Byrd-Mobile may be required to allow for clearance.
- Remove the lower RFA crossbars.
- Hold the left C-plate, remove the 6 fasteners holding the Titanium Links to the C-plates, and remove the C-plate.
- Hold the right C-plate, remove the 6 fasteners holding the Titanium Links to the C-plate, and remove the C-plate.
- Remove tagline and travelling ground as required.
- Connect Spectrometer Vacuum Pump using procedure HSI_MIT_022.
- Remove Titanium Links.

4.10 Spacecraft Demate from Launch Vehicle

- Disconnect Spectrometer Vacuum Pump using procedure HSI_MIT_023. **IMPORTANT: SPACECRAFT MAY NOT BE DISCONNECTED FROM VACUUM PUMP FOR MORE THAN 15 HOURS.**
- Remove 3 S/C Balance Weights which interfere with Titanium links.
- Remove ties holding the pigtail harness.
- Install Debris Shields to prevent bolts and washers from falling into spacecraft and 3rd stage.
- Install Titanium Links.
- Install tagline and travelling ground to spacecraft.
- Attach the right C-plate to the Titanium Links using 6 fasteners.
- Attach the left C-plate to the Titanium Links using 6 fasteners.
- Attach the lower RFA crossbars to the C-plates.
- Position one person at each corner of the Byrd-mobile and one person to watch for clearance. Push the Byrd-Mobile under the spacecraft and line it up.
- CAUTION: RFA Side plates have a very small clearance to the spacecraft solar arrays. Identify one person responsible for preventing contact between S/A and RFA plates as they are being attached.
- Attach the two RFA side plates to the RFA C-plates.
- Attach RFA side plates to the Byrd-mobile.
- Attach RFA side plates to the lower crossbars.
- Attach RFA upper crossbars.
- Raise the Byrd-mobile to allow the spacecraft weight to be transferred to the Byrdmobile from the launch vehicle.
- Remove the fasteners, specified in OSC procedure PWP-5040, 38" Separable Payload Installation procedure which hold the spacecraft and separation ring to the launch vehicle.
- Move the spacecraft and Byrdmobile approximately 6" from the Pegasus-XL third stage avionics section.
- Disconnect pigtail harness.
- Move the spacecraft away from LV and remove Payload Attach Fitting according to Orbital procedure.
- Move spacecraft to target destination.

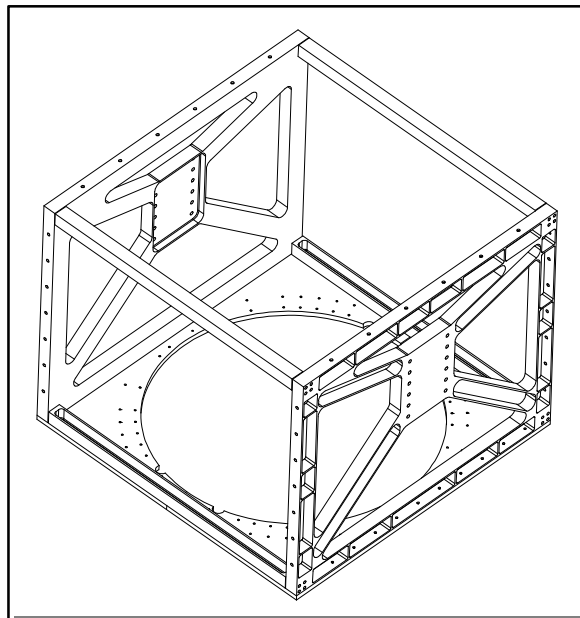

Rollover Fixture Adapter (RFA)

